

PRF SERIES Inline Planetary

PRF 120 1-Stage Dimensions

Input bore size $\leq \varnothing 19$ mm

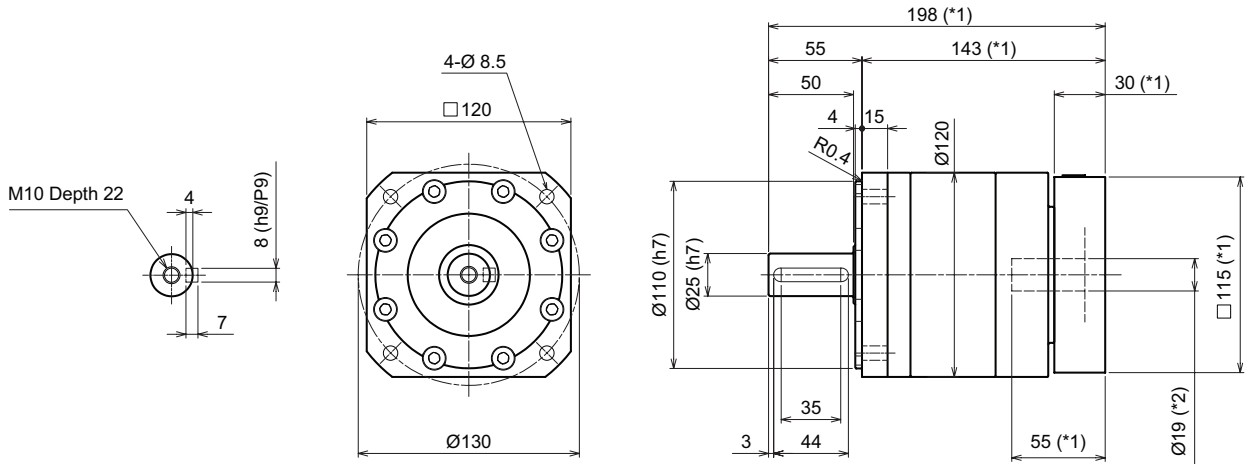

Input bore size $\leq \varnothing 28$ mm

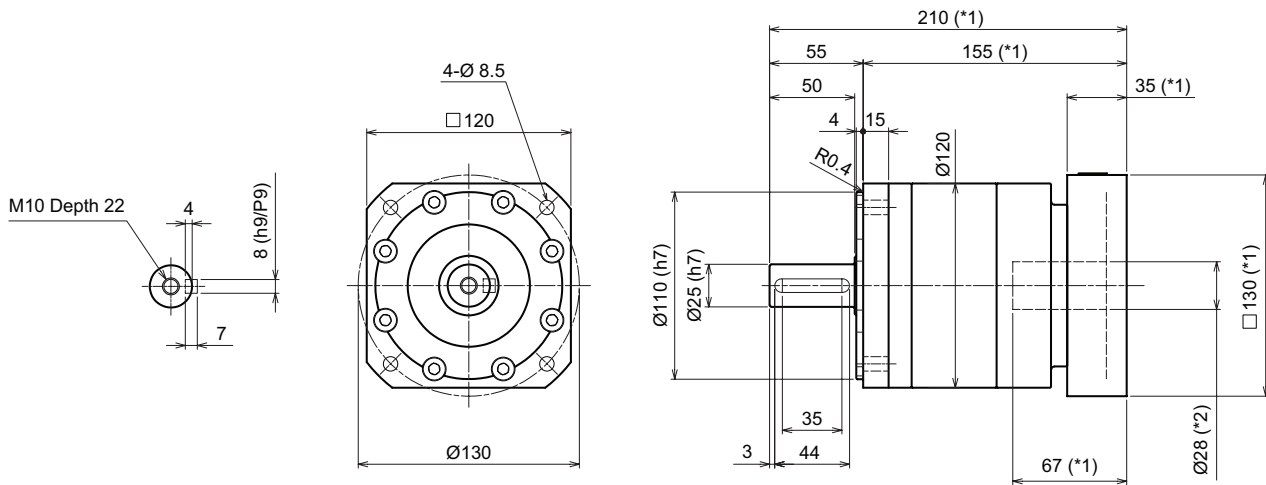

Input bore size $\leq \varnothing 38$ mm

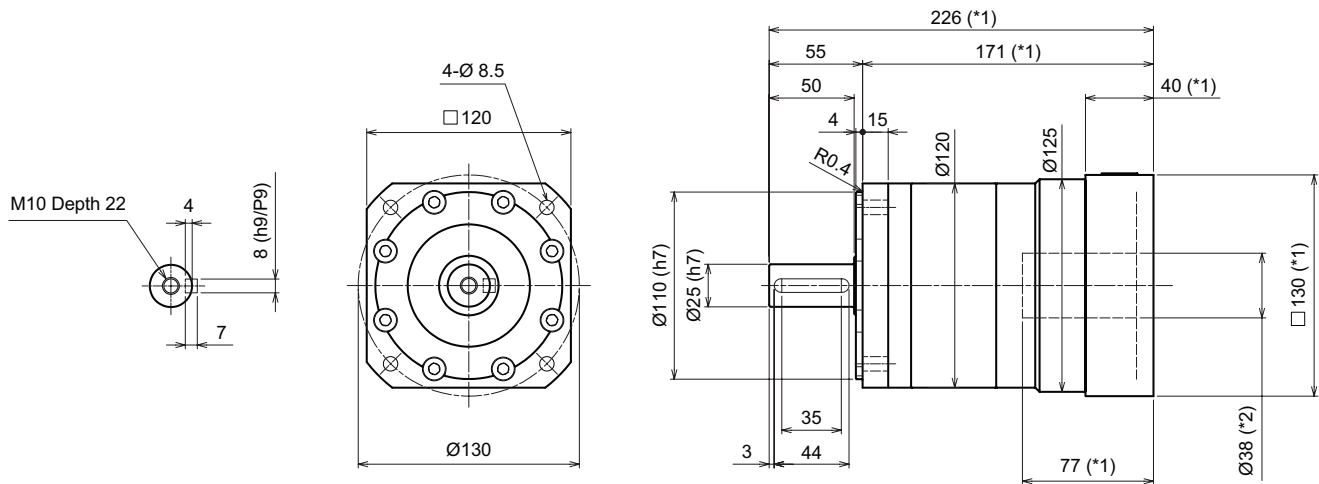

*1) Length will vary depending on motor

*2) Bushing will be inserted to adapt to motor shaft

PRF 120 2-Stage Dimensions

Input bore size $\leq \varnothing 19$ mm

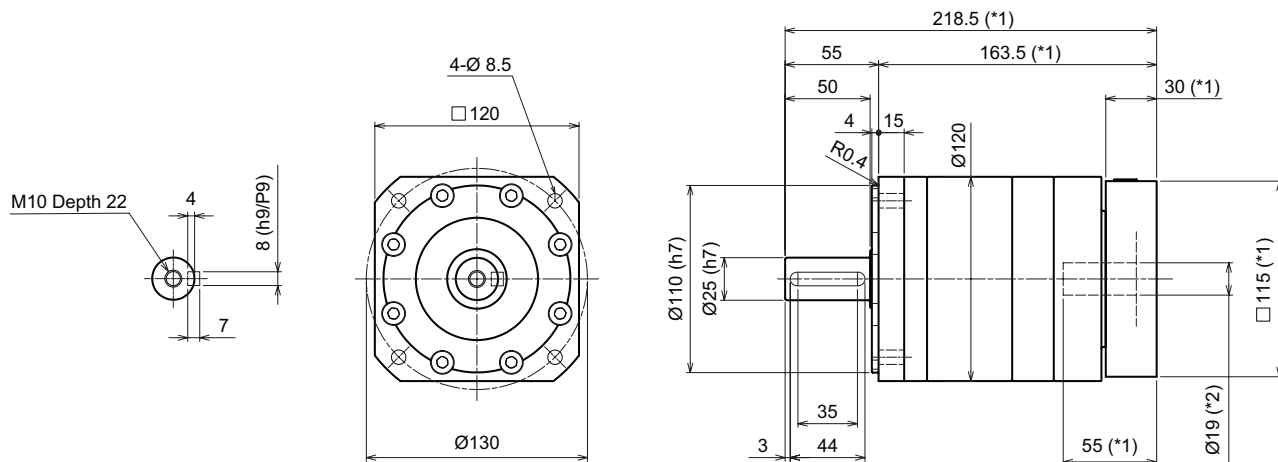

Input bore size $\leq \varnothing 28$ mm

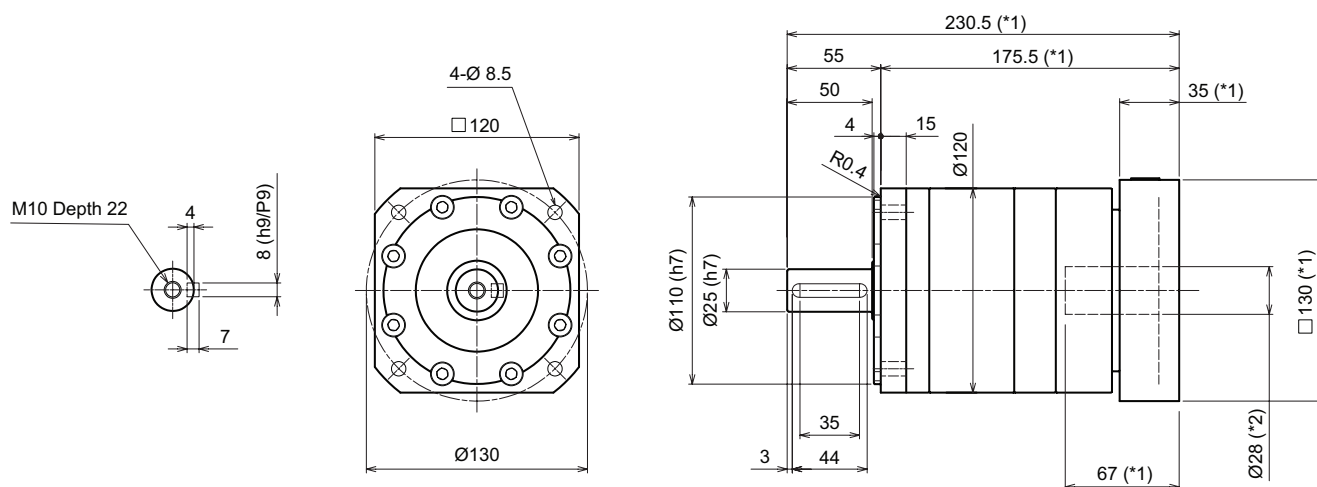

*1) Length will vary depending on motor

*2) Bushing will be inserted to adapt to motor shaft